

# EVOLUTION





***PowerBox Systems*** <sup>®</sup>

**Dear customer,**

We are delighted that you have decided to purchase the **PowerBox Evolution** from our range.

We wish you every success with your new **PowerBox Evolution**, and hope you have loads of fun with it.

## **1. Product description**

The **PowerBox Evolution** is a modern power supply system containing all the electronic components required to power modern receivers, servos and models. Every single element, ICs, micro-controller and electronic circuit which is essential to a reliable power supply is **duplicated!**

### **Features:**

- Dual regulated output voltage
- Enlarged heat-sink area for even higher performance
- Signal amplification for a total of six channels
- Three voltage indicator LEDs
- Minimum value memory displays any voltage collapses which occur in-flight
- Support for three battery types: LiPo, NiMH / NiCd, LiFe
- Suppression of any servo feedback currents which might occur

This range of functions makes the **PowerBox Evolution** the ideal battery backer for large model aircraft with wingspans in the range 2.0 m to 2.6 m, as well as helicopters and gliders.

## 2. Controls:

The illustration below shows the essential control elements:

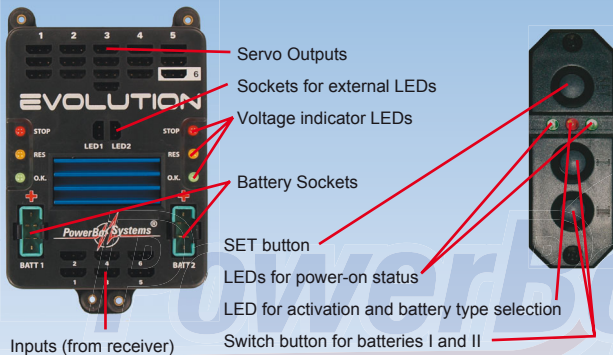

**SensorSwitch** socket - connect as shown



### 3. First steps, the unit in use

#### a) Connections

- First plug in all the servos to the desired channels. The channel assignment is left up to you; for example, input 4 corresponds to output 4.
- Connect the receiver to the **PowerBox Evolution** using the six patch-leads supplied in the set. Power is fed to the receiver via these leads.
- Now connect the **SensorSwitch** to the appropriate socket on the unit, ensuring that the ribbon cable faces up as shown. In models subject to severe vibration we recommend that you secure the ribbon lead by at least one additional point to avoid the connector working loose. If the connector were to fall out, it would have no effect on the switched state of the backer, but would prevent you switching the system off.
- The optional ultra-bright external LEDs can now be connected to the unit. We urge you to connect them and mount them in the fuselage side, as they enable you to detect battery problems when the model is flying.
- The final step is to connect the batteries to the backer's integral MPX connectors. We recommend the use of batteries or 1500 mAh or 2800 mAh capacity from **PowerBox Systems**. If you prefer to use other makes of battery, or wish to make up your own packs, it is absolutely essential to maintain correct polarity
- check twice rather than make a mistake! Connecting a battery with reversed polarity will instantly ruin the backer's regulators. In order to minimise power losses, the backer does not feature reverse polarity protection. The + (positive) indicator can be seen on the case cover.

#### b) The procedure for switching on and off

Switching the unit on and off is very simple, and the process effectively prevents accidentally changing the backer's status. This is the procedure:

Locate the SET button on the **SensorSwitch** and hold it pressed in until the central LED glows red. Now press buttons I and II in turn; the backer is now switched on. Repeat the procedure to switch off: hold the SET button pressed in, wait until the central LED glows red, then confirm by pressing buttons I and II in turn.

Once switched on, the backer can only be turned off again using the switch unit. Intermittent contacts or interruptions in the power supply cannot cause the backer to be switched off permanently.

### c) Setting the battery type

The default battery type setting is Lithium Polymer. If you wish to use two-cell LiPo packs, you therefore need to make no changes at this point. For all other battery types adopt this procedure:

- Switch both batteries on.
- Hold the SET button pressed in, and watch the central LED on the **SensorSwitch**.
- The LED will light up, and then go out again after a brief period.
- After a few seconds the LED emits one brief red flash. If you now release the button, you have selected the battery type LiPo.
- If you allow the LED to flash twice before releasing the button, you have selected five-cell NiCd / NiMH as the battery type.
- If you hold the button pressed in until the LED has flashed three times, the voltage indicator is prepared for LiFe (A123) packs.

This process only takes a few seconds, and is designed to eliminate the danger of accidental changes to the setting. In any case it only has to be carried out once, as your selected battery type is permanently stored in the backer's EEPROM.

#### d) Reading out the minimum value memory

The minimum value memory shows you the extent to which the battery voltage collapsed during the last flight. Control surfaces with a tendency to jam, stiff linkages, or simply batteries which fade under load, may be the cause of any problem in this respect. Please make it part of your routine to read out this minimum value memory after every flight, as this enables you to detect any weakness in the system before the next flight.

The method of calling up the memory is simple:

After the flight, press both switch buttons Battery I and Battery II simultaneously, and hold them pressed in as long as you like. The LED which now lights up indicates the lowest voltage value which occurred during the flight. The memory does not record voltage collapses which were of very short duration; only those lasting longer than one second.

#### e) Changing the output voltage 5.9 V / 7.4 V

You can set your **PowerBox Evolution** to either of two different output voltages. The default stabilised voltage is 5.9 Volts. If you wish to raise the voltage to 7.4 Volts, please check carefully that all the components in your model are designed and approved for the higher voltage.

In 7.4 Volt mode the dissipated power is lower, and this means that the power of your **PowerBox Evolution** is about 30% higher.

By default both voltage regulators are set to 5.9 V. If you wish to use high-voltage servos (HV servos, designed for up to 8.4 V), the **PowerBox Evolution** allows you to operate the servos on a regulated voltage of 7.4 V instead of 5.9 V. The advantage of a regulated 7.4 V voltage compared with an 'open' 8.4 V battery is that the regulated voltage causes all servos to work constantly at the same speed and generate the same torque. This is an important advantage which is particularly appreciated by all our competition pilots, as it makes all manoeuvres more predictable and easier to fly.

A further advantage of a regulated 7.4 V servo voltage is a longer effective life for your servos, as it eliminates the voltage peaks which occur when the batteries are freshly charged.

Setting the servo voltage:

The procedure for switching the unit to 7.4 Volts is quick and simple, and only needs to be carried out once. The setting is stored permanently, but can also be changed again at any time. The change must be carried out for **each of the two voltage regulators**, as the **PowerBox Evolution** features two regulators which work independently of each other.



To change the output voltage, connect both batteries and switch the **PowerBox Evolution** on.

Now disconnect **both** batteries from the **PowerBox Evolution**.

Press the **SET** button and **hold it pressed in**. With the **SET** button pressed in, reconnect Battery 1 and Battery 2.

The selected setting is indicated by the LED monitor on the **PowerBox Evolution**: all the LEDs on the appropriate side light up:

**1 x flash means that the regulator is now operating at 5.9 V**

**3 x flashes means that the regulator is now operating at 7.4 V**

The output voltage is switched by a toggle process. Example: the set voltage is 5.9V; if you connect the batteries with the **SET** button pressed in, the output voltage changes to 7.4 V, and the LEDs flash three times. If you wish to revert to 5.9 V, you must disconnect the batteries and repeat the procedure.

**Caution: it is essential that both regulators are set to the same voltage. If you set only one regulator to 7.4 V, the voltage at the output is 7.4 V.**

#### 4. Specification

Operating voltage:	4.0 Volt to 9.0 Volt
Power supply:	2 x 5-cell NiCd or NiMH batteries, 2 x 2-cell LiFe batteries (A123) 2 x 2-cell LiPo batteries, 7.4 Volt
Current drain:	Switched on: approx. 80 mA Switched off: approx. 4 $\mu$ A
Dropout voltage:	approx. 0.25 V
Max. receiver/servo voltage:	2 x 10 A (stabilised), according to cooling measures Peak 2 x 20 A
Servo sockets:	16 sockets, 6 channels
Temperature range:	-30°C to +75°C
Dimensions:	93 x 67 x 19 mm (incl. base plate)
Weight:	86 g
Sensor-Switch:	15 g
EMV approval:	EN 55014-1:2006
CE approval:	2004/108/EG
WEEE Reg. No.:	DE 639 766 11
Registered design:	DE 203 13 420.6

**This battery backer fulfils the EMV protective requirements, EN 55014-1:2006 with certificate dated 10 February 2009. EMC approval 2004/108/EG.**

**The unit must not be connected to a mains PSU!**

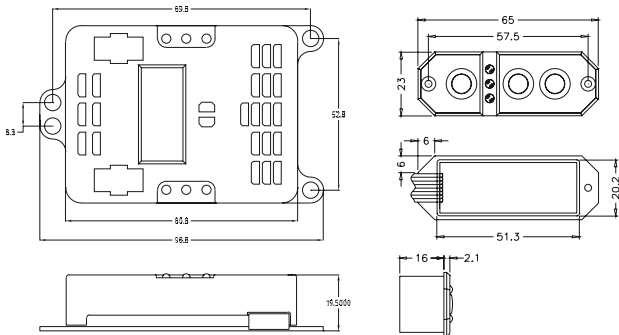

## 5. Set contents

- **PowerBox Evolution**
- **SensorSwitch**
- 6 patch leads
- 2 external LEDs
- 4 rubber grommets and brass spacers
- 4 retaining screws
- Operating instructions

## 6. Guarantee conditions

We take the maintenance of the highest quality standards very seriously. That is why **PowerBox Systems GmbH** is currently **the only RC electronics manufacturer certified to the Industrial Norm DIN EN ISO 9001:2008**.

As a result of this quality management, which applies to development and production, we are able to grant a guarantee of **36 months** on our products, commencing on the initial date of purchase. The guarantee covers proven material faults which occur during the guarantee period; such defects will be corrected by us at no charge to you.

**We expressly deny liability for damages which are caused by the device, or arise through the use of the device!**



*PowerBox*

### **Liability exclusion:**

We are not in a position to ensure that you observe our instructions regarding installation of the battery backer, fulfil the recommended conditions when using the backer, or maintain the entire radio control system competently.

**For this reason we deny liability for loss, damage or costs which arise due to the use or operation of the battery backer, or which are connected with such use in any way.**

We wish you every success using your new **PowerBox Evolution**, and hope you have loads of fun with it.

Donauwörth, July 2015



E. Altmann



**PowerBox-Systems®**

*World Leaders in RC  
Power Supply Systems*

**PowerBox-Systems GmbH**

**Certificated according to DIN EN ISO 9001:2008**

**Ludwig-Auer-Straße 5**

**D-86609 Donauwörth**

**Germany**

Tel: +49-906-22 55 9

Fax: +49-906-22 45 9

info@PowerBox-Systems.com

**www.PowerBox-Systems.com**